



QuickChange Camber Plate - Instructions

Part Number 2152200

Cars applicable:

'66-'89 911/912/930 – See instructions for strut insert compatibility. See instructions for use with coil over conversions.

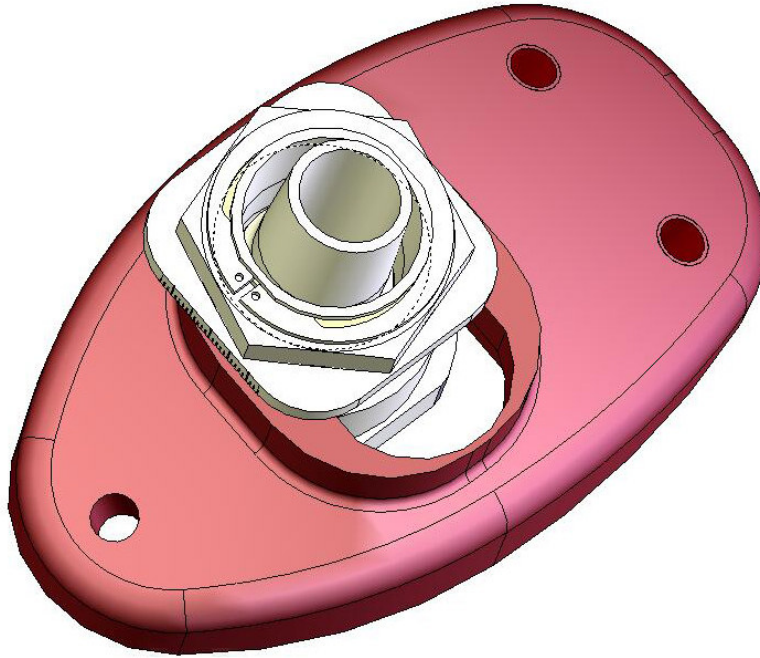

Figure 1 – QuickChange Camber Plate

Tools Required:

8mm hex key (allen head wrench)
1.75 inch socket wrench

Introduction:

Congratulations on your purchase of the QuickChange Camber Plate from Elephant Racing!

The QuickChange Camber Plate allows fast camber changes without altering caster. Built-in indices make it easy to change both passenger and driver sides equally, without a camber gauge.

You can quickly switch between street and track settings, or make track-side adjustments based on tire temperatures.

The QuickChange Camber Plate offers an increase range of camber adjustment, up to an additional 1.25 degrees.

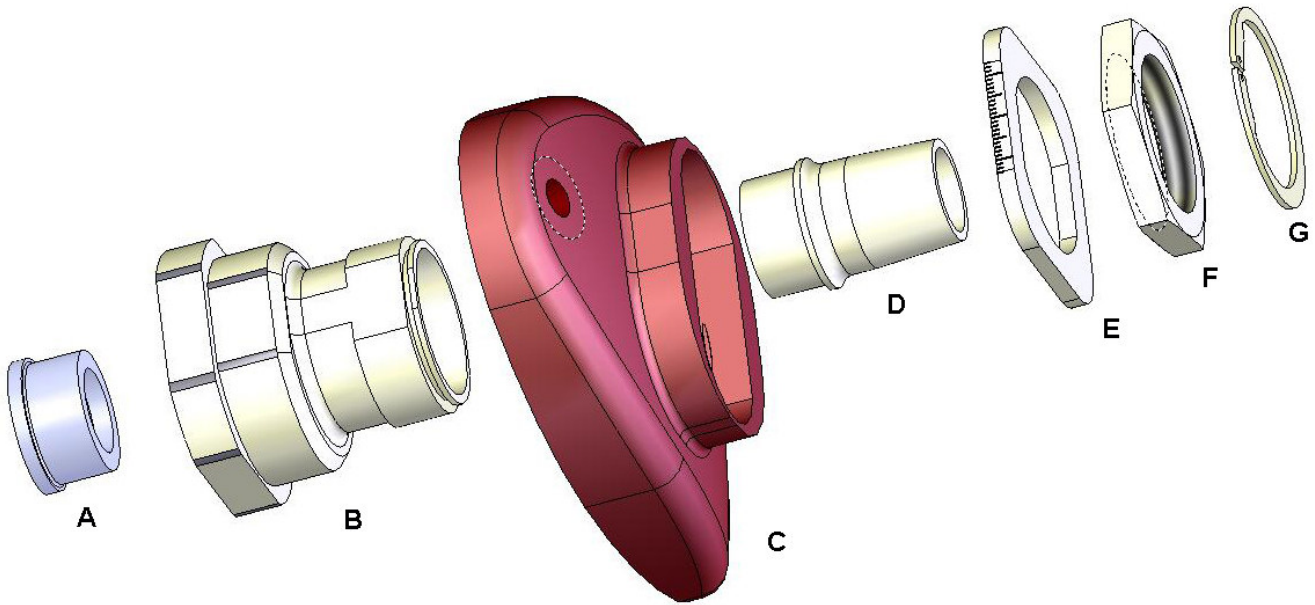

Figure 2 – QuickChange Camber Plate exploded view

Item #	Qty	Description	Torque
A	2	Optional Koni / Boge insert adaptor – available separately, do not use if you have Bilstein inserts	
B	2	Carrier assembly	
C	2	Plate	
D	2	Spacer	
E	2	Indexed washer	
F	2	Nut, 1.75 inch	75 ft/lbs
G	2	Retaining Ring	

Table 1 – Parts and torques

Installation:

Installation procedure is the same as for factory camber plates. Refer to a shop manual for details.

Re-use the factory mounting hardware.

Struts and inserts / limitations:

DO NOT install the strut-top dust covers (metal “cans” at the top of the strut). See Figure 5, showing installation without strut-top dust covers. You may optionally install rubber bellows to provide dust protection, available separately.

DO NOT use the QuickChange Camber Plates with the early-style Bilstein inserts illustrated in Figure 3. These inserts will not provide adequate thread engagement of the strut-top nut.

Do use the QuickChange Camber Plates with the late-style Bilstein inserts illustrated in Figure 4.

QuickChange Camber Plates may be used with coil over conversions. To use with coil over kits with Bilstein inserts, you must use Elephant Racing Extended Length Upper Spring Perches for QuickChange camber plate part number 2280902.

Koni and Boge strut inserts must use the Koni/Boge insert adaptor [A] shown in figure 2, available separately.

Bilstein inserts must NOT USE the Koni/Boge insert adaptor [A] shown in figure 2. No adaptor is used with Bilstein inserts.

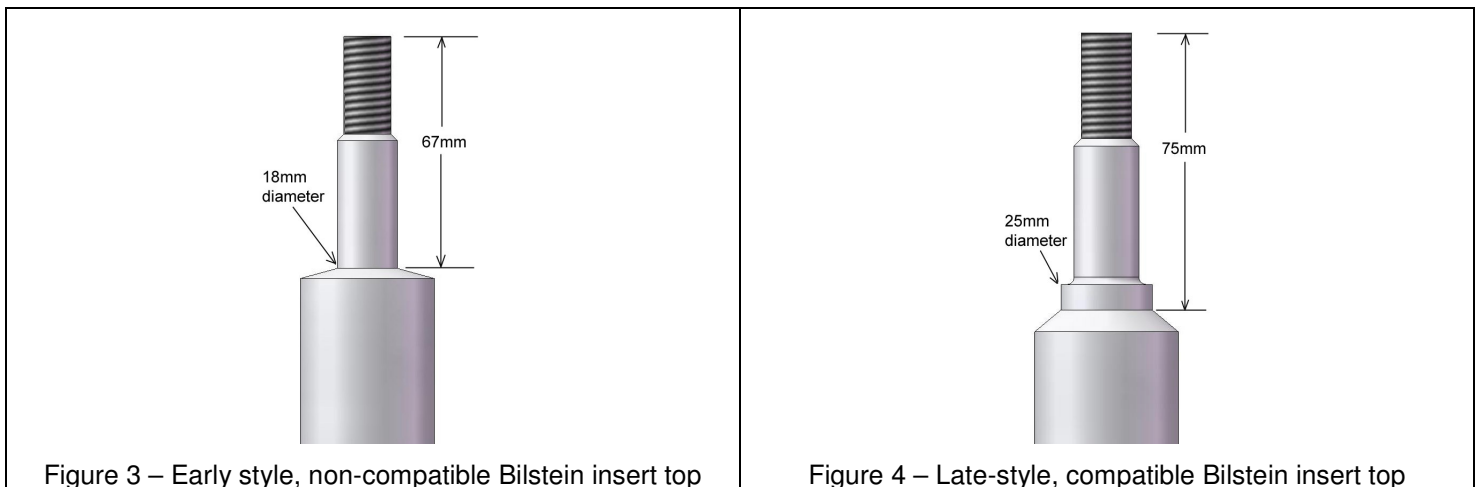

Figure 3 – Early style, non-compatible Bilstein insert top

Figure 4 – Late-style, compatible Bilstein insert top

Caster Adjustment:

Adjust caster using the normal factory procedure. Refer to your shop manual for details.

Camber Adjustment:

Refer to Figure 2. Remove Clip [G]. Use a 1.75 inch socket to loosen Nut [F]. Slide the Carrier assembly [B] to the desired position. Torque Nut [F] to the specification in Tab1. Install Clip [G].

While it is good practice to check your camber with a camber gauge, you can make relative changes without a gauge. Use the markings on Index Washer [E] to make measured and equal changes to both passenger and driver sides. There is a corresponding reference mark on the Plate [C]. This technique is valuable for making “track side” changes based on tire pyrometer readings.

This technique can also be used to maintain “street” and “track” camber settings and quickly change between them (write down the index position for each).

Note that camber changes will affect toe. Camber changes of .25 degrees or less have a small impact on toe. Changes of more than .25 degrees will cause a meaningful toe change and toe adjustment is warranted.

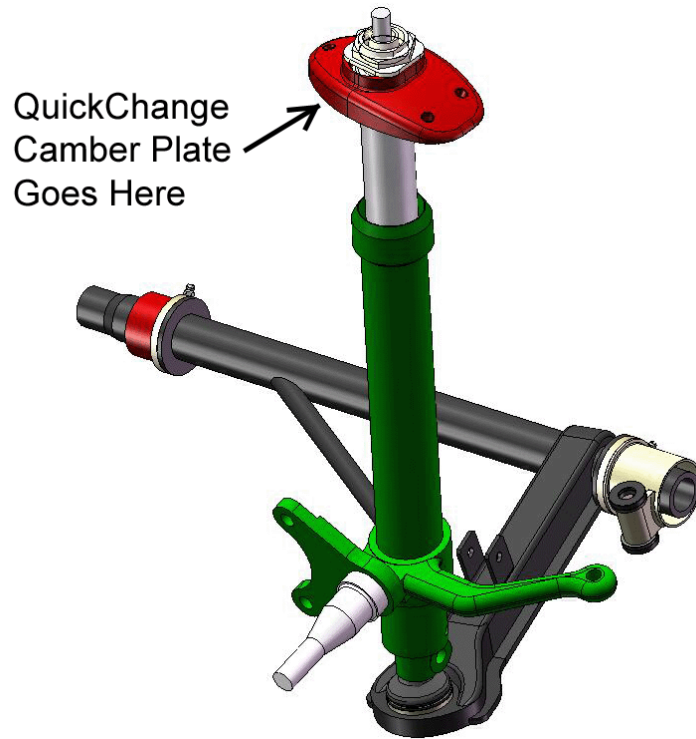

Figure 5 – QuickChange Camber Plate installed on Bilstein insert